

Style 97 Split Repair Sleeves

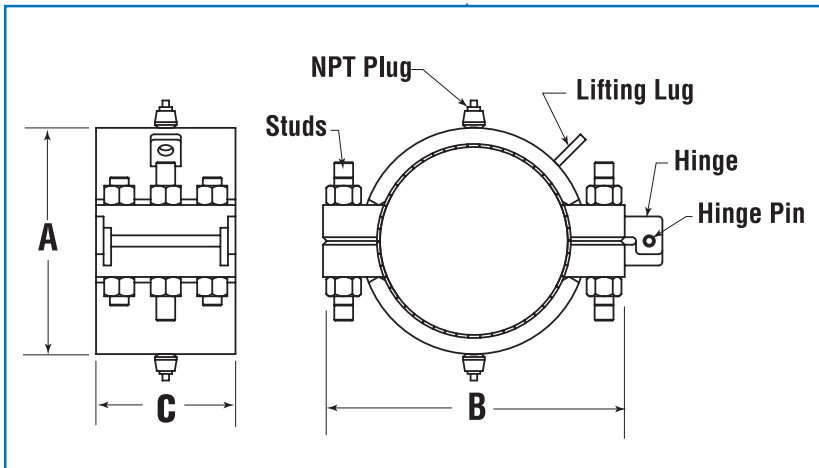

The **Dresser® Style 97 Split Repair Sleeve** is designed for fast, simple repair of pit holes, cracks or splits in high pressure steel pipelines up to 48” in diameter. Costing less than heavier sleeves now on the market, the Style 97 is also weldable offering your choice of a temporary or permanent repair. Stainless steel retainer rings and the lock-in gasket design ensures pressure-tight closure on the pipe with seal lengths of 5-inches (3-12”) and 8-inches (14-48”). For ease of installation, a hinge and pin assembly and lifting lugs are standard on all clamps 6” and above. All clamps feature a 1/2” NPT relief plug.

Style 97 sleeves come completely factory-assembled for quick installation. Fabricated from high quality carbon steel or manufactured from cast steel, all Style 97 repair sleeves are factory-tested to 1.5 times rated pressure.



Materials of Construction

- Body:** Carbon Steel to ASTM A515/516; Cast to ASTM 216
- Studs:** Carbon Steel to ASTM A193
- Hex Nuts:** Carbon Steel to ASTM A194
- Seal Retainer:** Stainless Steel
- Seals:** To Dresser Specifications. Durometer Hardness: 70; Tensile Strength: 1000 psi minimum
- Hinge Bracket:** AISI 1010 Steel
- Hinge Pin:** AISI 1018 Steel
- NPT Plugs:** Carbon Steel

Style 97 Split Repair Sleeve Specifications for Sizes 3” thru 48”

Nominal Size (In.)	Overall Diameter (A) (In.)	Overall Width (B) (In.)	NPT Plugs (In.)	Overall Length (C) (In.)	Seal Length (In.)	Approx. Weight Per Sleeve (Lbs.)
3	5.5	8.3	1/2	8.5	5	42
4	6.3	10.5	1/2	8.5	5	65
6	8.6	12.6	1/2	9	5	85
8	10.5	15	1/2	9	5	132
10	12.7	17.5	1/2	9	5	156
12	15	19.2	1/2	9	5	174
16	18.3	24.6	1/2	12	8	360
20	23	29.5	1/2	12	8	525
24	27	36.4	1/2	13	8	680
30	33.4	41.3	1/2	13	8	865
36	40.1	48.7	1/2	13	8	1300
42	47.3	56.5	1/2	15.5	8	2150
48	53.2	64	1/2	18	8	2890

Style 97 Pressure Ratings*
Size 3” - 48”
Up to ANSI 600 - 1440 psi

Temperature Ratings
-20° to +120°F

*NOTE: All Dresser Style 97 sleeves are factory-tested to 1.5 times the pressure rating.

Larger diameters, metric sizes and longer seal lengths are available on request. Please consult factory with your particular application requirements.

SUPPLIED BY:



Anode Engineering Pty Ltd | Engineering Services
P: 1800 446 400
E: admin@anodeengineering.com
www.anodeengineering.com

SUPPLIED BY:



Lordco New Zealand
P: +64 4 939 3944
E: sales@lordco.co.nz
www.lordco.co.nz