



Product Data

Style 220S Reinforcing Sleeve

The economical weldover sleeve for fast repair of 3/4" thru 2" small diameter steel pipe joints

The Dresser Style 220S weldover sleeve offers repair and reinforcement of threaded collars, welded or coupled joints in small diameter ID sizes. The smooth, contoured design and factory-beveled longitudinal edges facilitate field welding. A pre-drilled vent hole precludes pressure build-up during welding installations.

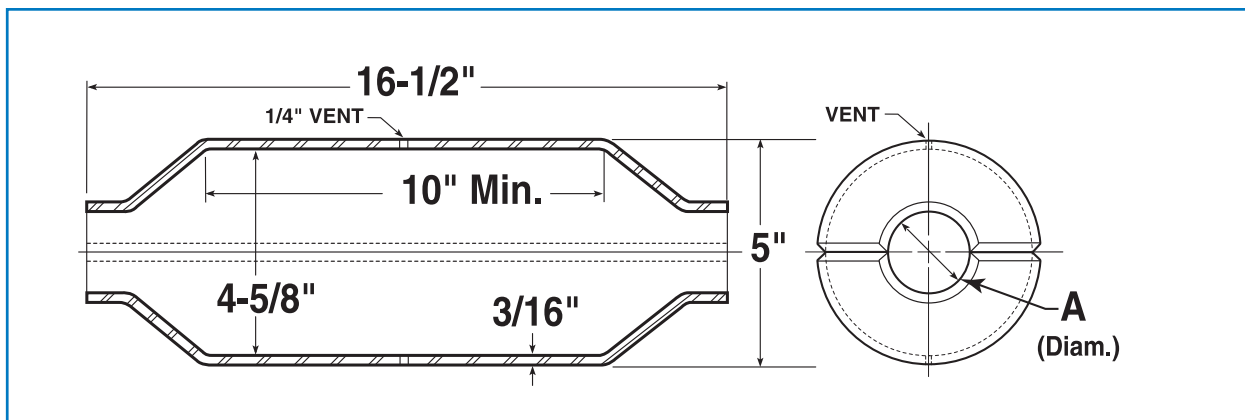

Pipe Size O.D. (In)	Nom. Size (In)	Diameter A (In)	Dresser Part Number
1.050	3/4	1-1/8	0220-0111-015
1.315	1	1-3/8	0220-0112-015
1.660	1-1/4	1-3/4	0220-0113-015
1.990	1-1/2	2	0220-0114-015
2.375	2	2-7/16	0220-0115-015

Dresser Style 220S Sleeves are rated to 350 psi working pressure and meet D.O.T. #192 code requirements. Please call your Dresser Regional Field Representative or your Dresser Inside Sales Customer Service Representative for further details.

Materials of Construction

Body: AISI C1012 Carbon Steel.
30,000 PSI Minimum Yield.

SUPPLIED BY:

ANODE
ENGINEERING
Anode Engineering Pty Ltd | Engineering Services
P: 1800 446 400
E: admin@anodeengineering.com
www.anodeengineering.com

SUPPLIED BY:

LORDCO
AN ANODE ENGINEERING COMPANY
Lordco New Zealand
P: +64 4 939 3944
E: sales@lordco.co.nz
www.lordco.co.nz