



DAIRYLAND ELECTRICAL INDUSTRIES

ALWAYS RUGGED. ALWAYS RELIABLE.

The Solid-State Decoupler (SSD) Installation Instructions

READ ENTIRE DOCUMENT BEFORE INSTALLING

Introduction

The Solid-State Decoupler (SSD) is a solid-state DC isolation/AC grounding (i.e., coupling) device designed for use in conjunction with cathodically protected equipment located in Class I, Division 2 hazardous (classified) locations or ordinary (non-hazardous) locations. The SSD is suitable for: (1) decoupling ground mats, (2) AC voltage mitigation, (3) over-voltage protection of insulated joints and similar structures and equipment, (4) DC isolation and AC grounding of cathodically protected structures and electrical equipment in cathodically protected structures.

The SSD can be used in a variety of different applications, each of which requires specific installation guidelines. These installation instructions cover the following common applications and arrangements.

- Over-voltage protection for insulated joints
- Decoupling gradient control mats
- Decoupling cathodically protected structures containing electrical equipment from grounding systems
- AC mitigation

Some applications listed may not apply in some countries due to different codes and practices. If your application is not covered by these installation instructions, contact Dairyland.

Technical information for applications is available on the [Dairyland website](#).

Installation Instructions

These general instructions apply to all applications.

Warning

Due to DC voltage, stray sources, or especially induced AC voltage on cathodically protected structures, personnel may be exposed to unsafe voltage. Measure for the presence of voltage before contacting the structure. NACE standard practice recommends caution and remediation when voltage approaches 15V between contact points. Sparking and current flow may occur when connecting or disconnecting decouplers

Model Number Chart

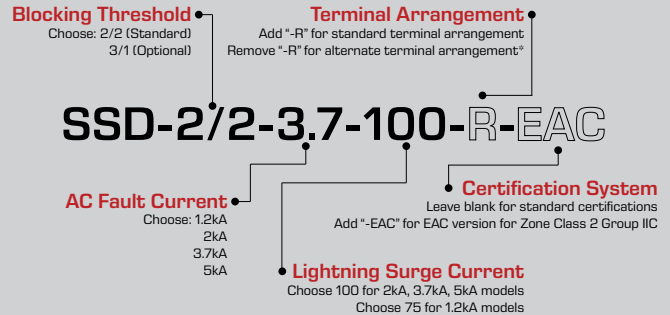

Note: For EAC products see separate EAC installation manual available at www.dairyland.com

Certifications

The SSD has been tested by Nationally Recognized Testing Laboratories (NRTLs) for compliance to independent standards in its operation, ratings, and construction. Visit our website for Complete Certifications and Listings

Safety Grounding

UL (United States) and C-UL (Canada) listing for:

NFPA 70 (US National Electric Code - NEC), Article 250.2 and 250.4 (A)(5), and CSA C22.1-12, Section 10-500 and 10-806. Over-voltage protection from lightning per ANSI C62.11.

Blocking Cathodic Protection Current

NFPA 70, Article 250.6(E)

Hazardous Location Use

The SSD has been certified for use in Class I, Division 2, Groups A, B, C, D hazardous locations to:

- NFPA 70 (U.S. National Electrical Code) sections 500-505
- ANSI/ISA 12.12.01-2011
- CSA C22.2 No.213-M1987 (R2008)

The SSD has been certified to ATEX Directive 94/9/EC and IECEx requirements for use in Zone 2, Group IIC hazardous locations by UL/DEMCO to: EN 60079-0:2012, EN 60079-15:2010, IEC 60079-0: 6th Ed, IEC 60079-15: 4th Ed

or over-voltage protectors. Assure that this does not occur in hazardous locations where gases or vapors may be present. All necessary precautions must be taken to avoid unsafe worker conditions, including arcing, in accordance with applicable industry and/or company-required practices.

Note: Explosion Hazard - Substitution of any component may impair suitability for Class I, Division 2.

Mounting

Mount the SSD so that the total length of conductor to the connection points will be as short as possible if the SSD is going to be used to provide over-voltage protection from lightning. All conductors have inductance which will cause a significant voltage per unit of conductor length when subject to lightning surge current. To minimize the voltage developed between the connection points, install the SSD as close as practical to the required connection points and cut the conductor to the shortest possible length during installation. For most insulated joint applications the SSD can, and should, be installed with less than 8" (200 mm) of conductor. Conductors can develop 1-3 kV/ft. (approx. 3-10 kV/meter) of length due to lightning; hence, for this reason, leads should be kept as short as possible in lightning applications. Conductor length is not critical for limiting voltage due to 50 Hz or 60 Hz current.

Mounting Accessories

Numerous mounting accessories are available from Dairyland to aid in the proper installation of the PCR. Full details and complete installation instructions are available on the Dairyland website here: [Dairyland Accessories](#).

Specific Installation Guidance

The Dairyland website contains detailed information on the installation methods specific to a given application. For wiring diagrams and/or application guidance, see [Dairyland Applications](#).

Environmental Exposure

The SSD enclosure is rated IP68 and is suitable for indoor or outdoor use, in submersible and non-submersible applications. SSDs may be submersed in non-freezing conditions up to 6.5 ft. (2 m) depth for occasional prolonged periods, though not continuously.

The unit must be installed in environments with ambient temperatures of -49° F to +149° F (-45° C to +65° C).

Polarity

If the SSD purchased has asymmetrical blocking characteristics and it is being connected between a cathodically protected structure and ground, connect the negative terminal of the SSD to the cathodically protected structure and the positive terminal to ground. If being connected between two different cathodically protected systems, attach the negative terminal to the more negative structure and the positive terminal to the less negative structure. A label on the SSD housing shows the polarity of each terminal.

Enclosure

The standard enclosure is rated IP68 to 2m depth (comparable to NEMA 6P). This enclosure is suitable for submersible applications.

Ambient Operating Temperature

-45°C to +65°C.

Field Testing

Before installation, the following measurements are suggested to confirm that the steady-state conditions imposed on the SSD will be within its ratings.

1. Measure the open-circuit DC voltage between the SSD connection points with a multimeter. The open-circuit DC voltage measured should be within the DC blocking voltage rating of the model selected (i.e., normally -3.0 V/+1.0 V or +/-2.0 V, unless a custom version has been ordered).

2. Measure the steady-state short-circuit AC-RMS current between the SSD connection points with a clamp-on ammeter. The short-circuit AC-RMS steady-state current measured should be less than the steady-state AC current rating of the SSD model ordered.

3. After installation, the DC voltage across the SSD terminals can be measured to confirm that the expected value of cathodic protection voltage exists, assuming the cathodic protection system is ON. (The voltage measured with a voltmeter will be less than the actual cathodic protection voltage because it is not being measured with respect to a reference cell.)

4. After installation, the steady-state AC current through the SSD conductors can again be measured. The current measured should be comparable to the value measured prior to installation since the AC impedance of the SSD is negligible (i.e., about 10 milliohms at 60 Hz).

5. To verify correct device operation while in service, measure the pipe to soil voltage using a reference cell. An acceptable CP reading will indirectly indicate correct operation with DC isolation, as device conduction would bond the CP system to ground (or to the other connected structure) and affect the CP reading. While an indirect test, it has proven to be a good indicator of operation. An unacceptable reading may be due to other factors besides the Dairyland device, and if needed perform the following additional tests.

6. The definitive test is one performed with the device out of circuit. If the device is in service, disconnect the CP structure attachment conductor (typically at the negative terminal) so that the product is isolated, but first addressing any safety issues such as adding a current-rated bonding jumper between the two connection points, wearing insulating gloves, etc. Note that if the Dairyland device is performing mitigation of induced AC voltage, disconnecting the device will leave the structure as an open circuit, and the induced voltage on the pipeline may rise to high levels. Therefore, take appropriate safety measures before proceeding. Next, momentarily short the device terminals to

remove any residual charge that may be on the internal capacitor. Connect a multi-meter, set to the lowest Ohms scale, across the terminals. If the product is functional, the resistance will start at zero ohms and then very slowly increase as the capacitor in the decoupler begins to charge from the multi-meter. The test may be discontinued at this point, as charging the capacitor can take up to 10 minutes, and it is only necessary to observe this general response briefly. If the product is failed, the reading will remain fixed and at a very low resistance value, typically a fraction of one Ohm.

If any measurements do not produce the expected results, contact Dairyland.

General Comments

The SSD does not require routine maintenance, but if the cathodic protection voltage level near the SSD is below the normal or expected value, it is suggested that the unit be field tested following procedures available from Dairyland.

If a problem is suspected, contact Dairyland for troubleshooting assistance. If repairs are necessary the unit is to be returned to Dairyland for diagnosis and repair after requesting a Return Material Authorization (RMA).

The SSD is designed to fail as a short-circuit to assure safety grounding at all times if the unit fails due to excessive ac fault current or lightning current beyond rating.

ATEX and IECEx Comments

- The device shall be placed into service in accordance with the ratings and limitations stated in the installation and operating instructions.
- No ongoing maintenance is required, as the device is designed to be maintenance-free, and is of solid-state construction with no moving, wearing, or serviceable parts.
- During installation the device should be handled and mounted in a location so that direct impact is minimized.
- Regular testing of the device is not required. Users who desire to verify the operating condition of the device should refer to the section entitled "Field Testing." Observe all safety precautions described, in addition to industry or company safety practices.
- **WARNING:** Potential electrostatic charging hazard – Plastic enclosures are to be cleaned or wiped only with a damp cloth.
- Products marked CE, Ex II 3 G are Equipment Group II, Equipment Category 3, and comply with the Essential Health and Safety Requirements relating to the design and construction of such equipment given in Annex II to the Directive 94/9/EC.

• This equipment is intended for use in area in which explosive atmospheres caused by gasses, vapors, mists, air or dust mixtures are unlikely to occur, or are likely to occur only infrequently and for short periods. Such locations correspond to Zone 2 classification according to ATEX Directive 94/9/EC.

• This equipment complies with standards EN 60079-0:2012 and EN 60079-15:2010 per certificate number DEMKO 05 ATEX 0431689X and IEC 60079-0 Ed. 6 and IEC 60079-15 Ed. 4, per certificate number IECEx UL 14.0021X. The Quality Assurance Report is based on ISO/IEC 80079-34: Edition 1 2011-04.

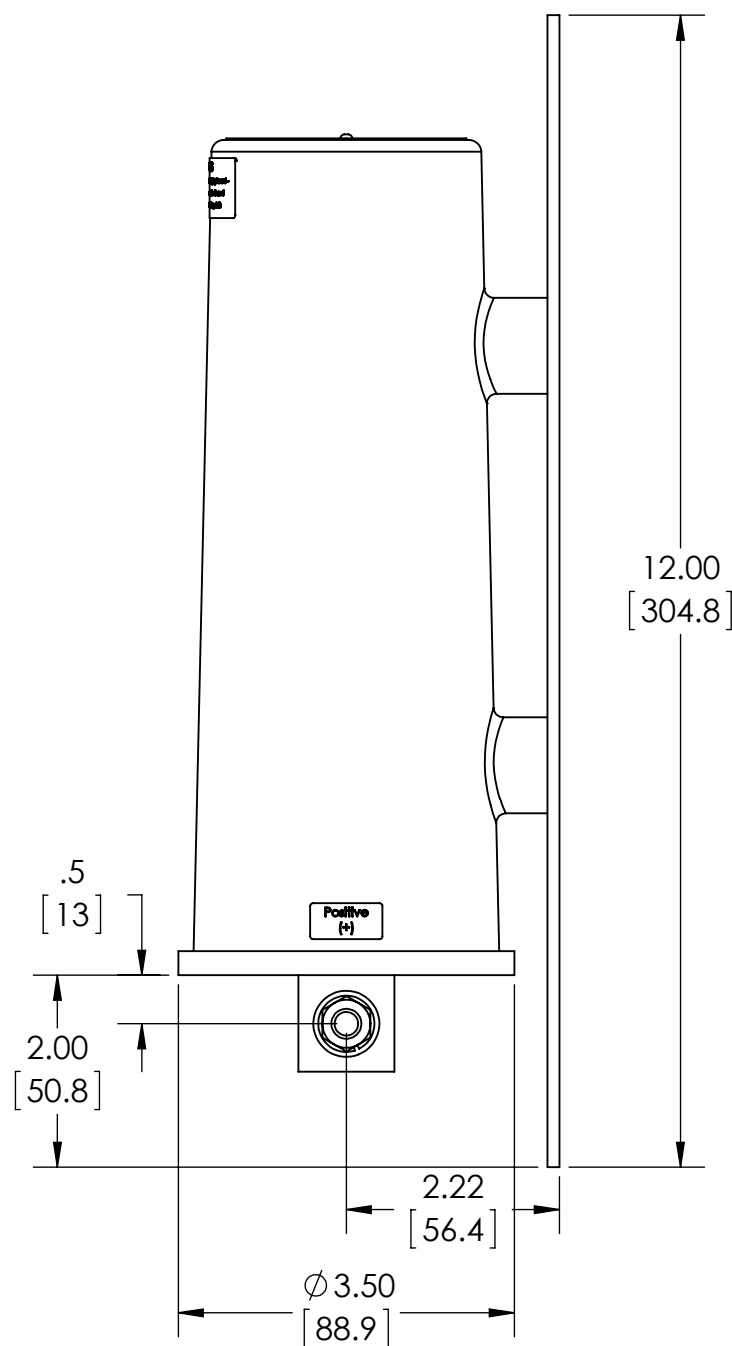
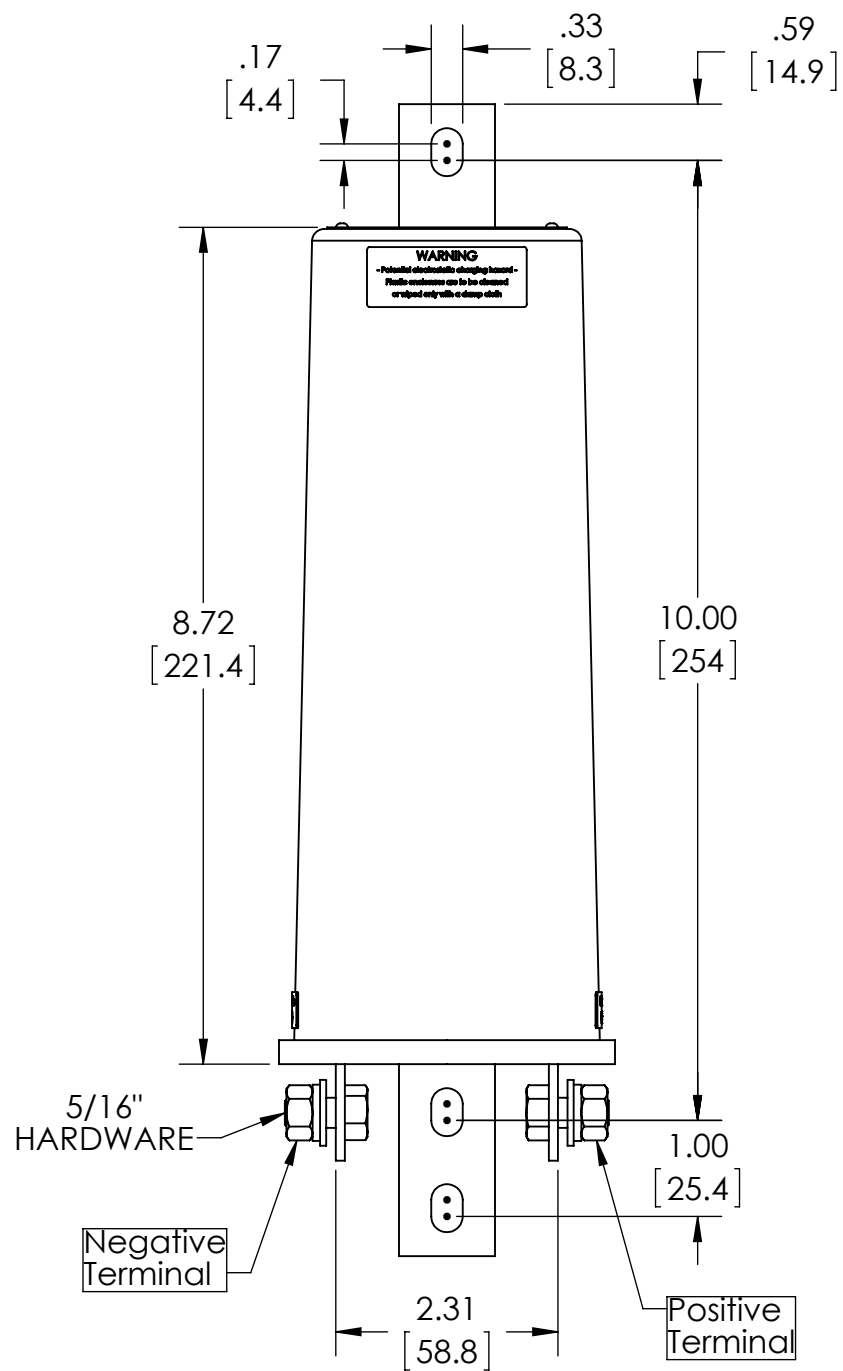
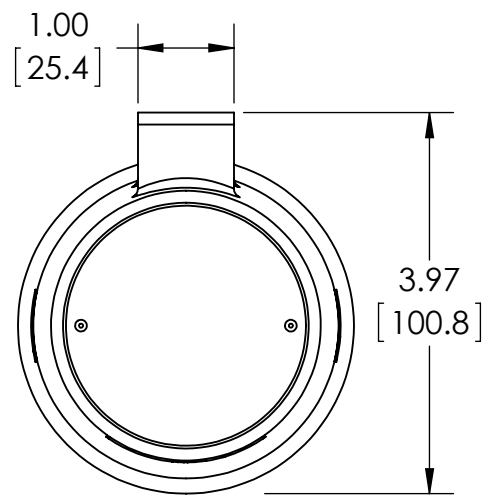

NOTE: Applies to all SSD models with standard terminal arrangement (-R model numbers)

ANSI Y14.5M 1994 APPLIES
 UNLESS NOTED
 UNITS: INCHES
 3-PLACE: ±.005
 2-PLACE: ±.015
 1-PLACE / FRAC: ±.03
 ANGULAR: ±1



**DAIRYLAND
 ELECTRICAL
 INDUSTRIES, INC.**
 P.O. BOX 187
 STOUGHTON,
 WI 53589
 608-877-9900
 DAIRYLAND.COM

| DESCRIPTION | | | | |
|--|------------|---------------|-------------------|---------------|
| SSD Outline Drawing - All Models with Standard Terminals | | | | |
| DOCUMENT # | REV | DATE DRAWN | DWG SIZE | DATE APPROVAL |
| 100074 | A | 2015-04-08 | B | 2015-04-10 |
| SCALE 1:2 | DRAWN: JPW | SHEET: 1 OF 1 | DWG APPROVAL: HNT | |

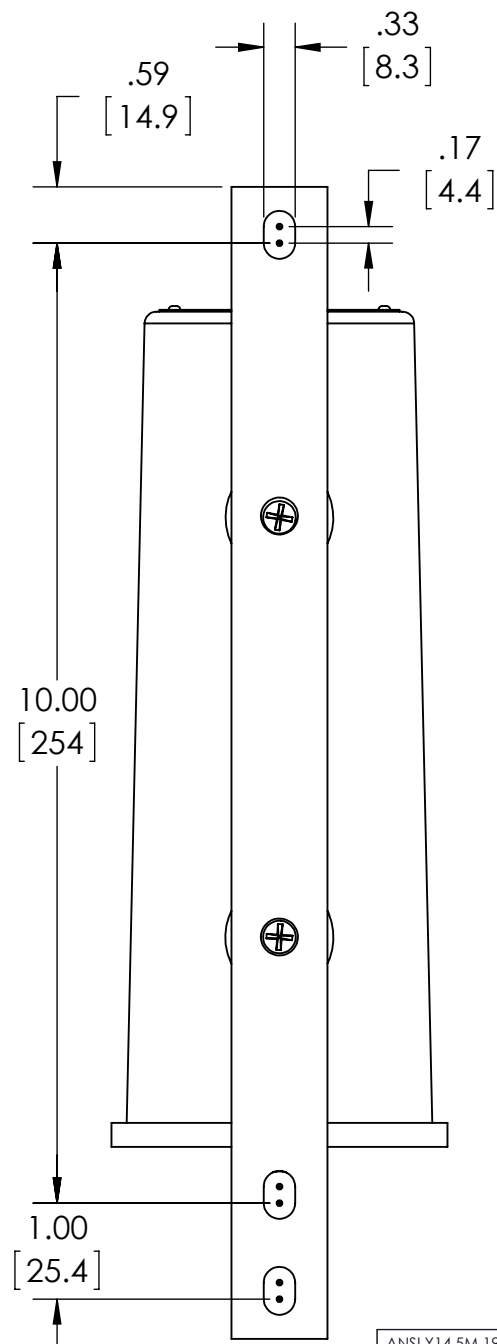
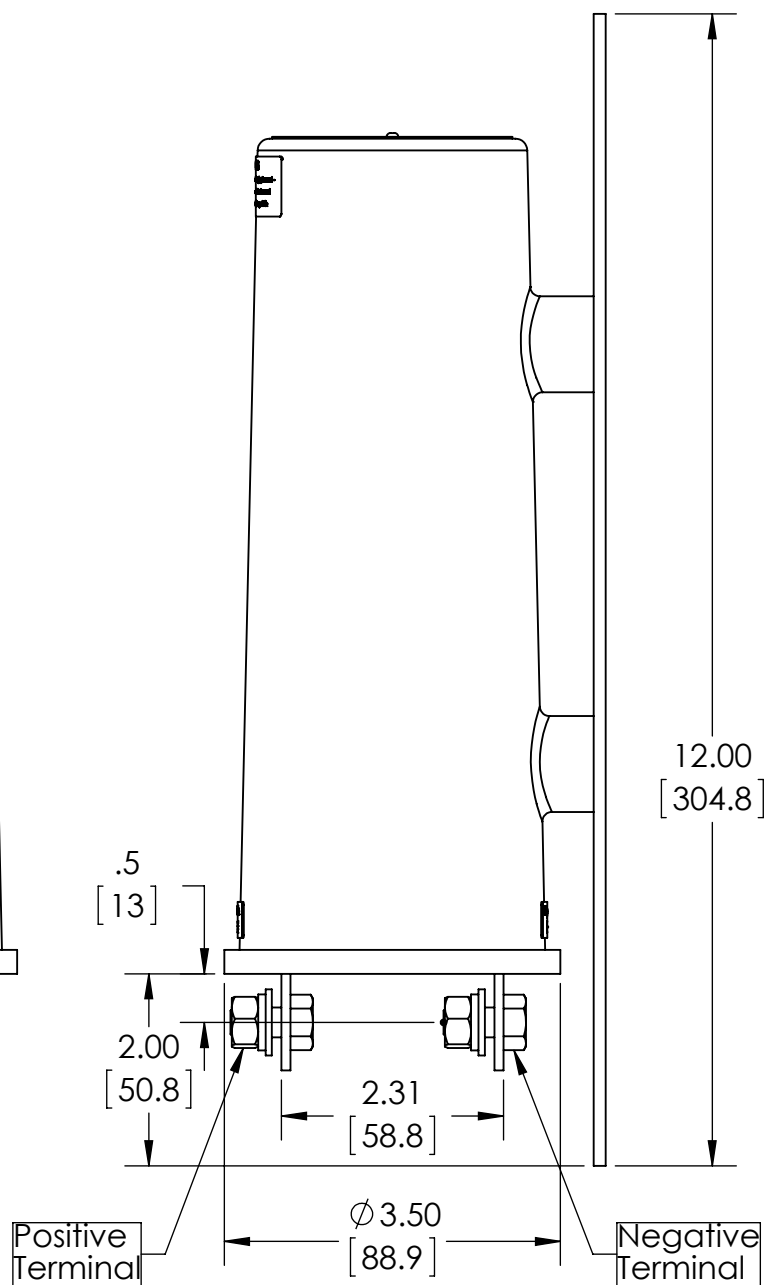
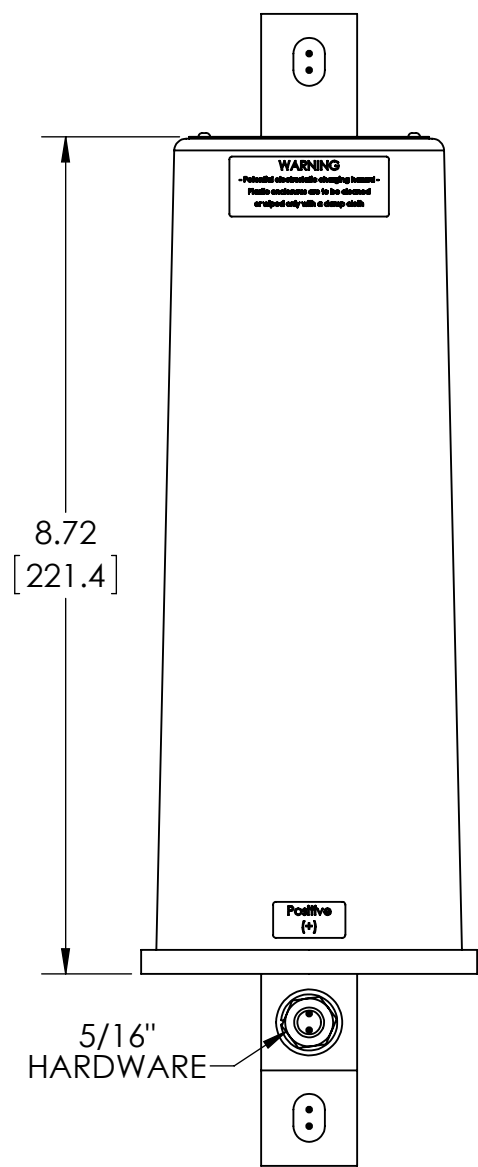
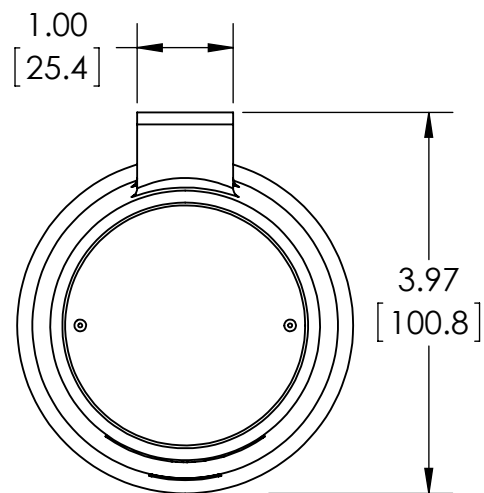

NOTE: Applies to all SSD models with an optional terminal arrangement (non -R model numbers)

ANSI Y14.5M 1994 APPLIES
 UNLESS NOTED
 UNITS: INCHES
 3-PLACE: ±.005
 2-PLACE: ±.015
 1-PLACE / FRAC: ±.03
 ANGULAR: ±1



DAIRYLAND ELECTRICAL INDUSTRIES, INC.
 P.O. BOX 187
 STOUGHTON, WI 53589
 608-877-9900
 DAIRYLAND.COM

| DESCRIPTION | | | | |
|--|------------|---------------|-------------------|---------------|
| SSD Outline Drawing - All Models with Optional Terminals | | | | |
| DOCUMENT # | REV | DATE DRAWN | DWG SIZE | DATE APPROVAL |
| 100075 | A | 2015-04-08 | B | 2015-04-10 |
| SCALE 1:2 | DRAWN: JPW | SHEET: 1 OF 1 | DWG APPROVAL: HNT | |